

QUICKEST WAY TO CUT WELDING COSTS

Increased productivity without capital investment or increased labor costs just has to spell PROFIT. Hundreds of resistance welding users are profiting from the TUFFALOY methods of multiple welding, to produce almost any assembly requiring closely spaced welds.

The key is to **“think multiple!”** Whenever the welding machine goes through a cycle, have it do more than one weld at a time. It’s easy and practical with one of the TUFFALOY multiple welding devices: The Teeter-Tip dual tip adapter, the Equatip dual tip holder, the Equa-Press dual tip holder, or the Tri-Spacer.

They’re ready to go to work, cutting costs and increasing production efficiency for you.

Study the multiple welding holders and adapters in this section. Learn their capabilities, **“think multiple,”** and you’ll probably see many ways in which TUFFALOY multiple welding can improve your operation. Remember that TUFFALOY is prepared to provide any special fixturing you need. Show our engineers what you require, and they’ll design a set-up to do it.

TEETER-TIP DUAL TIP ADAPTERS

U.S. Pat. 3,356,821

You can spot or projection weld in half the time by doubling the number of welds per machine stroke. Use Teeter-Tip dual tip adapters, which come with water-coolant fittings to beat high heat build-up. These adapters transmit total pressures of 1000 lbs., and deliver equal current and pressure to each tip. They compensate for normal electrode wear, imperfect tip dressing, and work variations up to .060”.

LIGHT-DUTY adapters have no. 4 or 5 RW shanks, tip spacing to 4 inches, tip sockets for 1/2” or 5/8” diameter male Tuffcap caps, or 4 RW tips (5/8” cap sockets are standard).

HEAVY-DUTY adapters have shanks from 5 to 7 RW size, tip spacing to 6 inches, tip sockets for 1/2” or 5/8” diameter male Tuffcap caps, or 4 or 5 RW tips (4 RW sockets are standard). These adapters have a deeper, stronger body.

Two low-height 5/8” dia. cap-type tips are shown below. They are recommended for use in these adapters. Other standard caps, both 5/8” & 1/2” dia., are tabled on the next page. You must specify the size tip sockets you want, or the standard socket will be supplied.

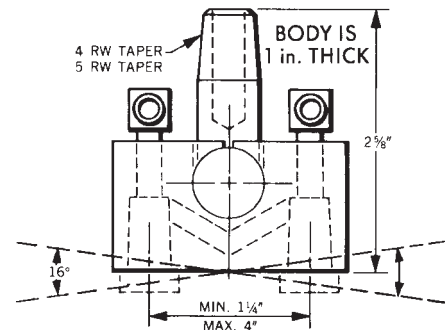

LIGHT DUTY

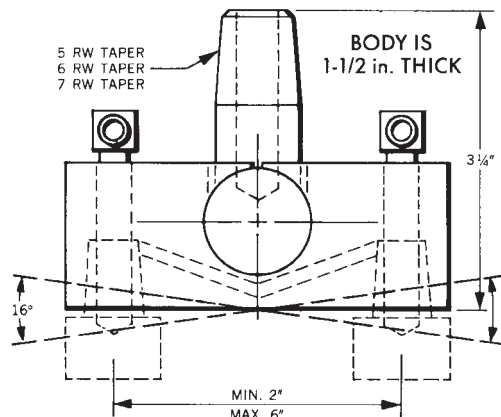

HEAVY DUTY

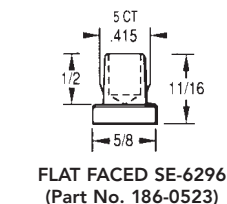
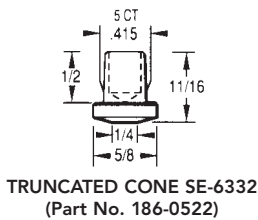

Style	Shank Taper	Description*	Tip Spacing Range (inches)	Socket Taper
LIGHT Duty	4RW	TT-1408	1-1/4 to 2	4RW 4CT 5CT
	4RW	TT-1416	2 to 4	4RW 4CT 5CT
	5RW	TT-1508	1-1/2 to 2	4RW 4CT 5CT
	5RW	TT-1516	2 to 4	4RW 4CT 5CT
HEAVY Duty	5RW	TT-15516	2 to 4	4RW 5RW 4CT 5CT
	5RW	TT-15524	4 to 6	4RW 5RW 4CT 5CT
	6RW	TT-15616	2 to 4	4RW 5RW 4CT 5CT
	6RW	TT-15624	4 to 6	4RW 5RW 4CT 5CT
	7RW	TT-15716	2 to 4	4RW 5RW 4CT 5CT
	7RW	TT-15724	4 to 6	4RW 5RW 4CT 5CT

*When ordering, also state exact tip spacing and tip socket size, Example: TT - 1508 - 1-1/2 - 5CT. (5CT means 5/8” diameter cap, 4CT means 1/2” diameter cap.)

